



Wilson Tool International

United States Worldwide Headquarters

12912 Farnham Avenue
White Bear Lake, MN 55110 USA
Tel: (651) 286 6001
Fax: (651) 286 5959
email: marketing@wilsontool.com

United Kingdom European Headquarters

Stirling Road, South Marston Industrial Estate,
Swindon, Wiltshire, SN3 4TQ, United Kingdom
Tel: +44 (0) 1793 831818
Fax: +44 (0) 1793 831945
email: sales@wilsontool.eu.com

France

Bat B
51 Rue D'Ourdy
77550 Réau, France
Tel: +33 (0)1 64 13 47 80
Fax: +33 (0)1 64 13 47 81
email: ventes@wilsontool.eu.com

Germany

Gottlieb Daimler Str 2
31552 Rodenberg, Germany
Tel: +49 5723-7470
Fax: +49 5723-74710
email: verkauf@wilsontool.eu.com

Scandinavia

Islevdalvej 100
DK-2610, Rødovre, Denmark
Tel: +45 44 53 16 99
Fax: +45 44 53 06 07
email: sales@wilsontool.dk

China

No. 6 Building of 58, 4018 Lane Huaning Road
Xinzhuang Industry Park, 201108 Shanghai, China
Tel: +86 21 51089638
Fax: +86 21 64422195
email: sales@wilsontool.cn

email: sales@wilsontool.eu.com
Visit us online at: www.wilsontool.com



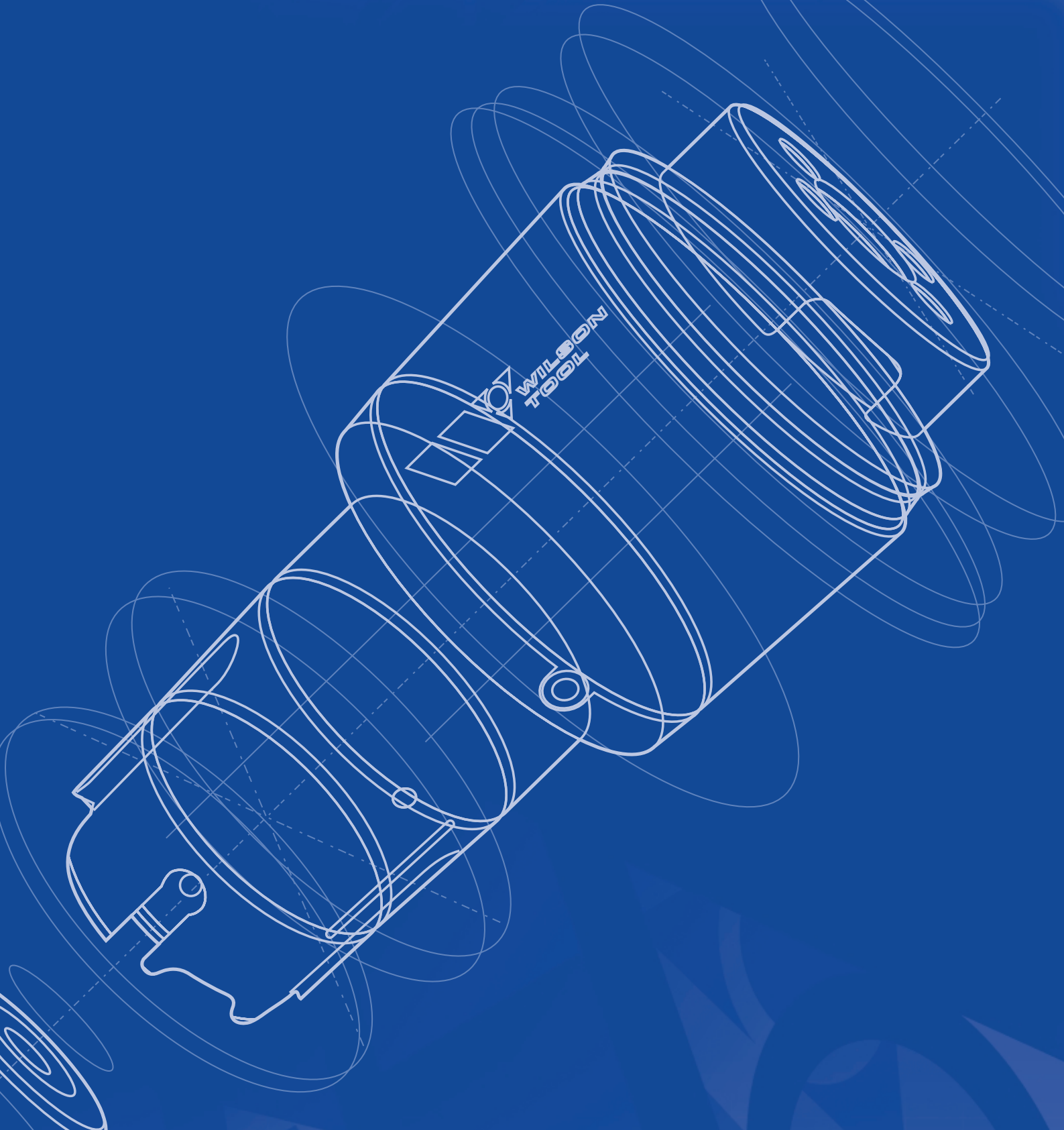

Wilson Tool

Replacement Amada Tooling



Terms and Conditions

Order	Minimum order is
Credit	All orders are subject to the approval of our credit department. If you are a new account, please furnish us with a bank reference and three supplier references. A credit limit will be imposed on new accounts until credit has been established.
Payment	Terms are net 30 days.
Cancellation	In the event an order is cancelled, charge will be made to cover labour, materials and overheads.
Returned Material	A handling charge of 25% is made on all standard parts returned for credit. Written permission and shipping instructions must be obtained before the return of any material. Special tooling cannot be returned.
Claims	All claims for shortages must be made within 3 days of the invoice date.
Prices	Prices and specifications subject to change without prior notice. E & OE. All prices are exclusive of VAT.

Table of Contents

Optima™ Coating	2
Ultima™ Tool Steel	3
Features and Benefits of Wilson Replacement Amada Tooling – Quick-Adjust A & B Stations	4
Features and Benefits of Wilson Replacement Amada Tooling – C, D & E Stations	5
Wilson Amada Style Quick Adjust A Station	6
Wilson Amada Style A Station	7
Wilson Amada Style Quick Adjust B Station	8
Wilson Amada Style B Station	9
Wilson Amada Style C Station	10
Wilson Amada Style D Station	11
Wilson Amada Style E Station	12
Close to Clamps Tooling	13
Replaceable Insert Assembly	14
Punch and Die Shims	15
Non Standard Keying	16
Shear Options	17

Technology for Increased Tool Life

Optima Coating

The New Standard in Tooling Performance!

Optima™ is a proprietary TiCN (titanium carbo-nitride) coating that was custom engineered at our in-house coating facilities. It features unique properties that significantly enhance tooling performance. This coating, which is available only to Wilson Tool customers, provides a level of surface hardness, wear resistance and lubricity never before associated with coated or uncoated punch press tooling.

Some of the many benefits that you will enjoy with our Optima™ coating include:

- Longer tool life
- Increased wear resistance
- More hits between sharpenings
- Reduced adhesion (galling)
- Reduced slug pulling
- Reduced corner breakdown
- Improved special tooling performance
- Lower overall tooling costs
- In-house coating facilities allow us to deliver faster and maintain total quality control



Punch Life

Nibbling 14ga. (1.9mm) 304 Stainless Steel

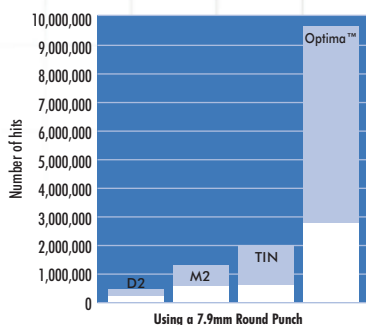

Using a 7.9mm Round Punch
The white area indicates actual results achieved through three tool sharpenings of 0.25mm each. The complete graph indicates projected results with a total of 6mm removed for sharpening.

Material Adhesion

Square mm of Material Adhesion (Galling) on Punch Tips

Nibbling 12ga. (2.1mm) Aluminium

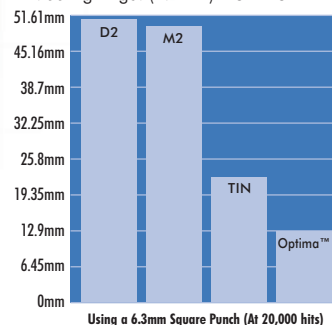

Using a 6.3mm Square Punch (At 20,000 hits)

Number of Hits

Number of Hits Before First Sharpening

Nibbling 14ga. (1.9mm) 304 Stainless Steel

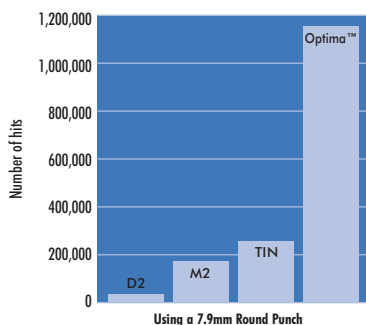

Using a 7.9mm Round Punch

Tip Wear

Punch Tip Corner Wear

Nibbling 14ga. (1.9mm) 304 Stainless Steel

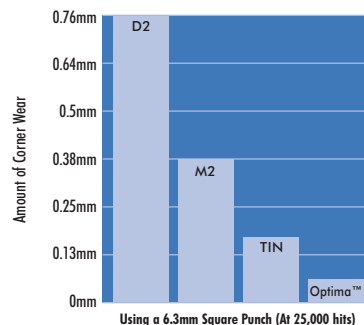

Using a 6.3mm Square Punch (At 25,000 hits)

Optima

TECHNOLOGY AT THE CUTTING EDGE

Ultima Tool Steel

Boost Punching Productivity!

Tool Steel for Longer Life

When faced with demanding applications that require long-term wear resistance and toughness, turn to Wilson's new Ultima™ Premium Tool Steel for HP thick turret tooling. Ultima punches and dies are engineered to increase wear resistance by up to 100% over conventional tool steels.

A New Level of Performance

Ultima premium tool steel sets a new benchmark for durability and performance. Ultima punches and dies are designed to dramatically improve tool life when punching abrasive materials and materials with high tensile strength.

Ultima excels in applications in which punches and dies wear quickly and is ideal for long running tasks. The premium steel from which Ultima punches and dies are made significantly reduces micro chipping on the cutting edge. This micro chipping is most often where cutting edge failure begins.



Remarkable Downtime Reductions

With up to twice as long between re-grinds, Ultima premium steel significantly reduces downtime and tool replacement costs. Breaking, chipping, cracking, tool fatigue and other downtime problems are minimised, providing long term gains in productivity and profitability.

Ultima tools are especially useful for the toughest punch press applications, but are effective in any job. Viability can be determined by conducting a cost benefit analysis.

Maintenance and sharpening may differ from traditional tooling. Please check with your local Sales Engineer or the Salesdesk.

Ultima[™]
PREMIUM TOOL STEELS

Quick-Adjust A & B Stations

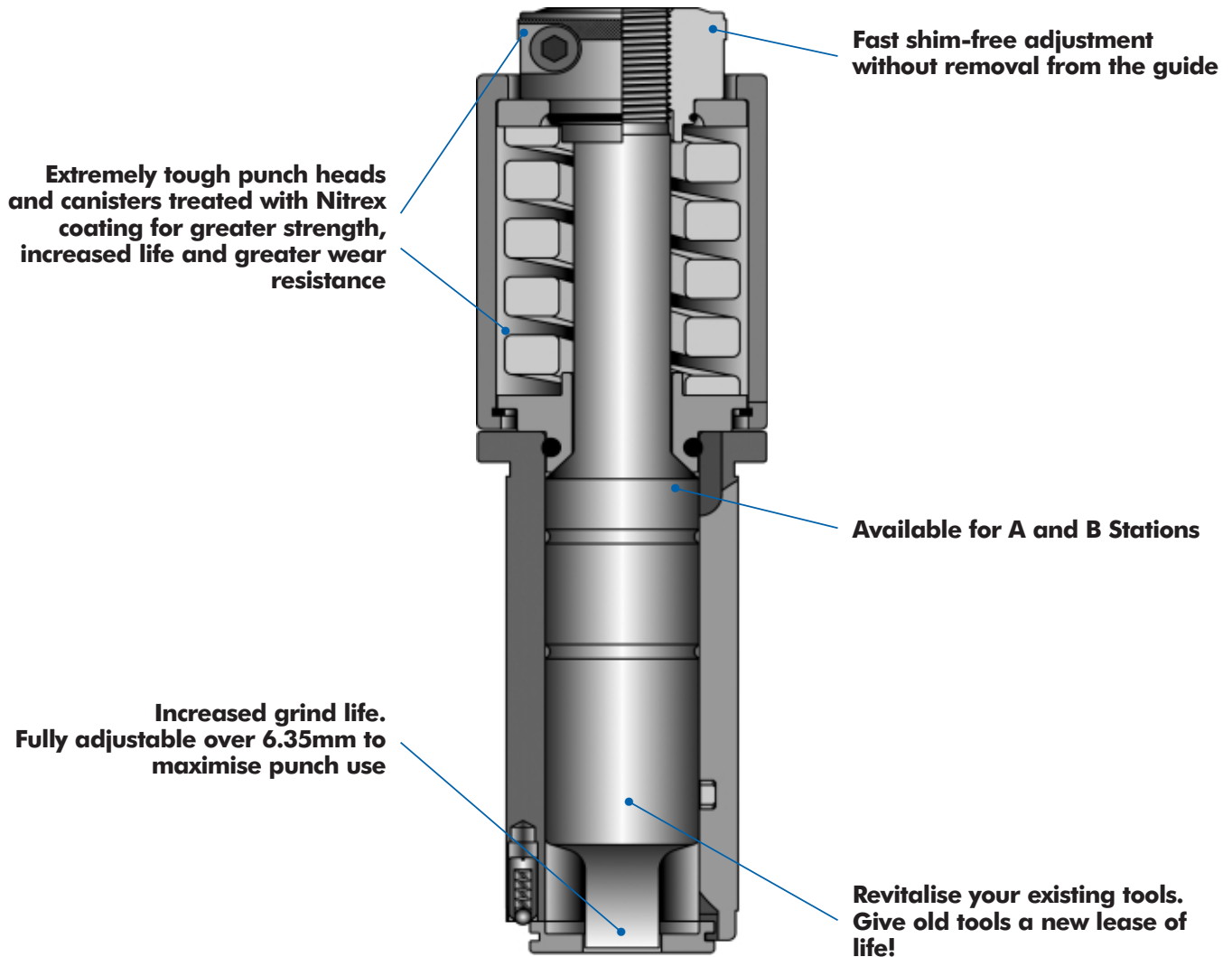

Features and Benefits of Wilson Replacement Amada Tooling

C, D & E Stations

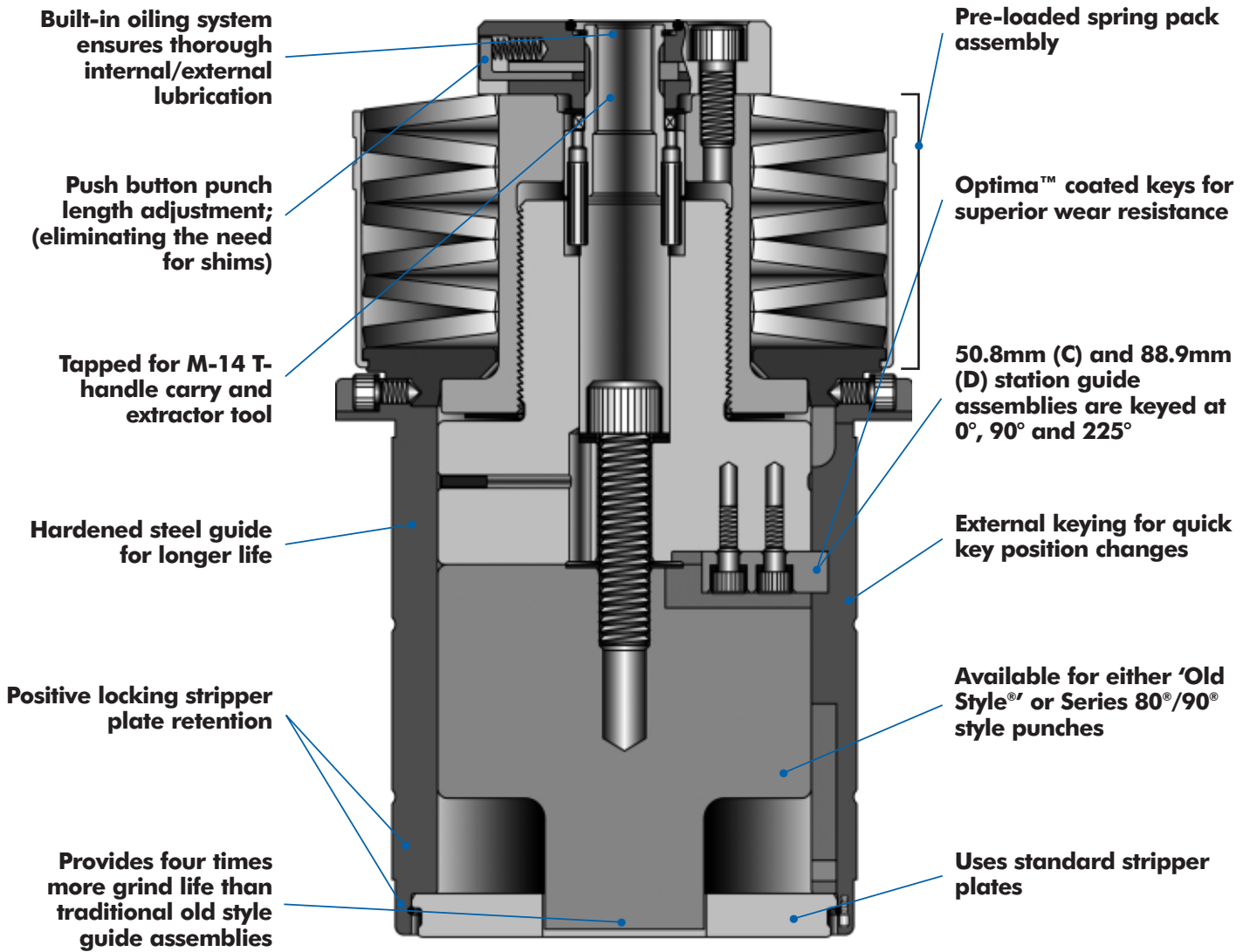

Wilson Amada Style Quick Adjust A Station

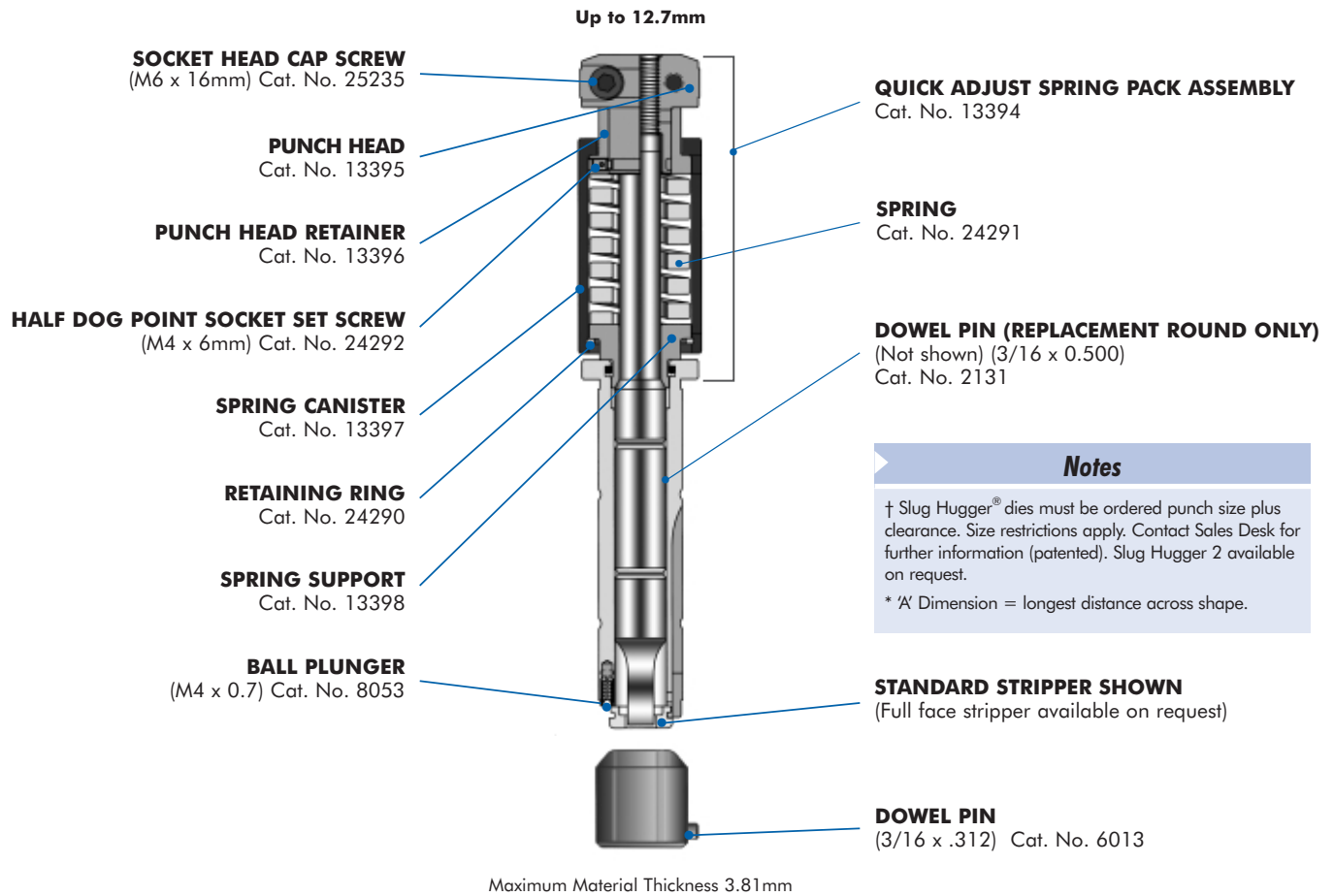

Notes

† Slug Hugger® dies must be ordered punch size plus clearance. Size restrictions apply. Contact Sales Desk for further information (patented). Slug Hugger 2 available on request.

* 'A' Dimension = longest distance across shape.

STANDARD STRIPPER SHOWN
(Full face stripper available on request)

DOWEL PIN
(3/16 x .312) Cat. No. 6013

Description	Cat. No.	Price
Punch & Guide Assembly	• Round	13425
	• Shape Fitted	13427
	• Optima® Add On	-
Punches	• Round	2183
	• Shape	2182
	• Optima® Add On	-
Guides	• Round	13065
	• Shape (0°)	13066
	• Shape (0° & 45°)	13067
	• Shape (0° & 90°)	13068
Stripper	• Round	13044
	• Shape Fitted	13143
Dies	• Round Slug Hugger®†	2192
	• Round Standard	1808
	• Shape Slug Hugger®†	2193
	• Shape Positive	1817
	• Shape Negative	1818
	• Ultima™ Add On (Round)	-
	• Ultima™ Add On (Shape)	-

12.7mm (A) Station Add Ons			
Add ons for Rounds			
Small Diameter	Punch	Die	Stripper
0.79 - 1.50mm			N/C
Clearance < 0.10mm			N/C
Add ons for Shapes			
Small Widths	Punch	Die	Stripper
0.79 - 1.0mm			
Clearance < 0.10mm			
Add to round or shape punch for extra straight before radius, extra back taper, or no back taper.			

Stubby Style (A) Station Add Ons		
	Punch	Die
 <p>Note: Must use stubby style die and guide with stubby style punch</p> <p>Use Standard Punch and Die Price Plus:</p>	Round (2.3mm max dia.) add	Round add
	Shape add	Shape add

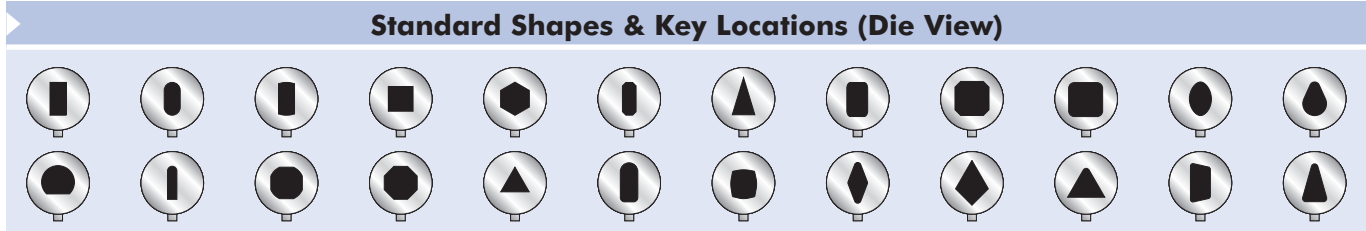

Wilson Amada Style A Station

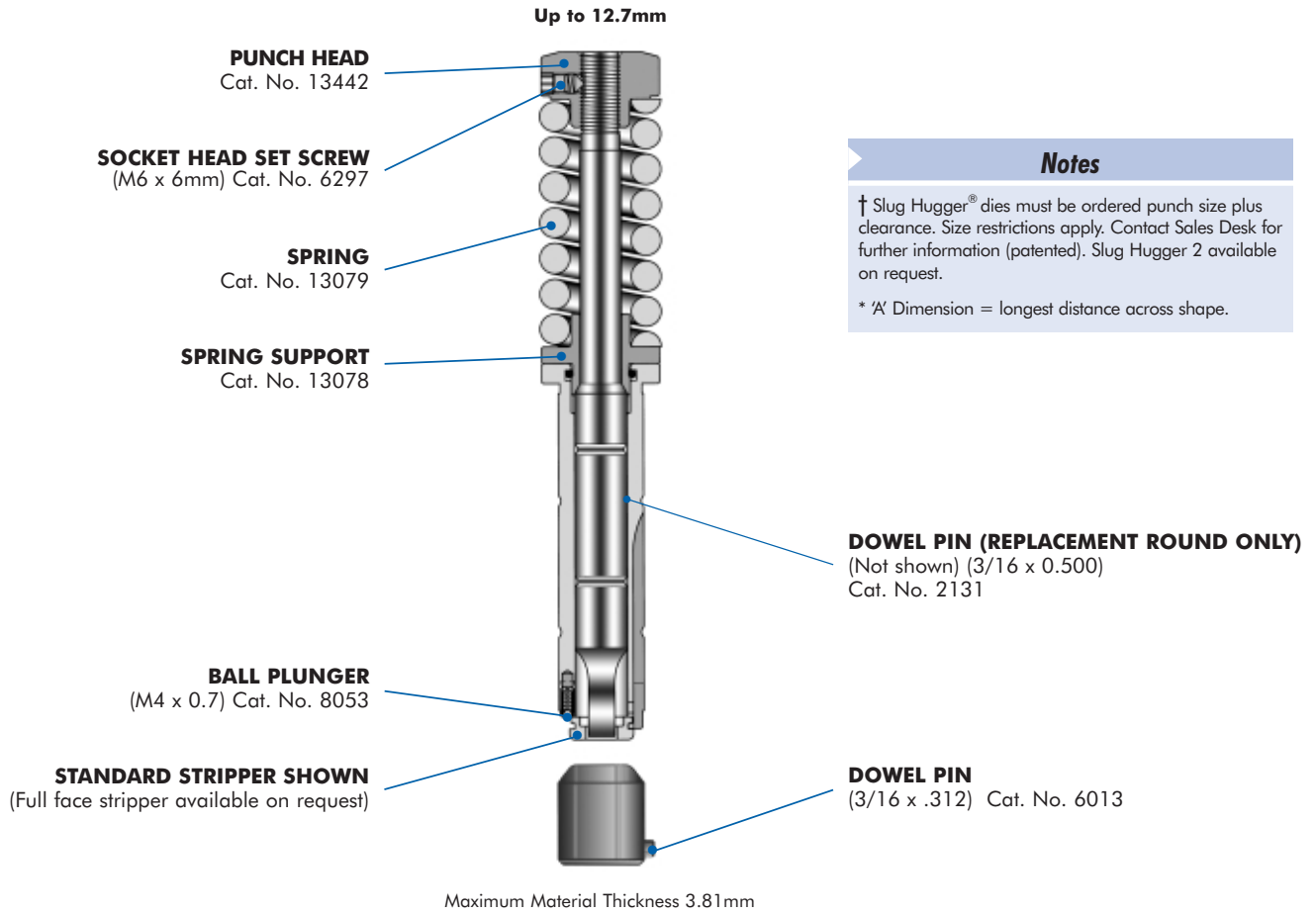

Notes

† Slug Hugger® dies must be ordered punch size plus clearance. Size restrictions apply. Contact Sales Desk for further information (patented). Slug Hugger 2 available on request.

* 'A' Dimension = longest distance across shape.

Description	Cat. No.	Price
Punch & Guide Assembly	• Round	13057
	• Shape Fitted	13059
	• Optima® Add On	-
Punches	• Round	2183
	• Shape	2182
	• Optima® Add On	-
Guides	• Round	13065
	• Shape (0°)	13066
	• Shape (0° & 45°)	13067
	• Shape (0° & 90°)	13068
Stripper	• Round	13044
	• Shape Fitted	13143
Dies	• Round Slug Hugger®†	2192
	• Round Standard	1808
	• Shape Slug Hugger®†	2193
	• Shape Positive	1817
	• Shape Negative	1818
	• Ultima™ Add On (Round)	-
• Ultima™ Add On (Shape)	-	

12.7mm (A) Station Add Ons			
Add ons for Rounds			
Small Diameter	Punch	Die	Stripper
0.79 - 1.50mm			N/C
Clearance < 0.10mm			N/C
Add ons for Shapes			
Small Widths	Punch	Die	Stripper
0.79 - 1.0mm			
Clearance < 0.10mm			
Add to round or shape punch for extra straight before radius, extra back taper, or no back taper.			

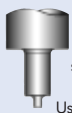
Stubby Style (A) Station Add Ons		
	Punch	Die
 <p>Note: Must use stubby style die and guide with stubby style punch</p> <p>Use Standard Punch and Die Price Plus:</p>	Round (2.3mm max dia.) add	Round add
	Shape add	Shape add

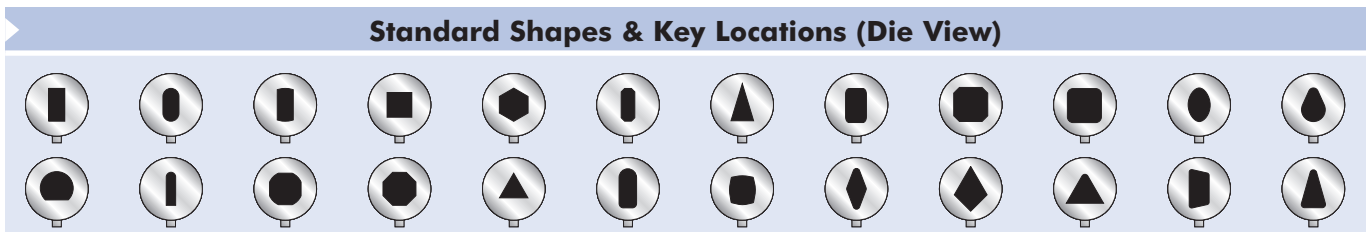

Wilson Amada Style Quick Adjust B Station

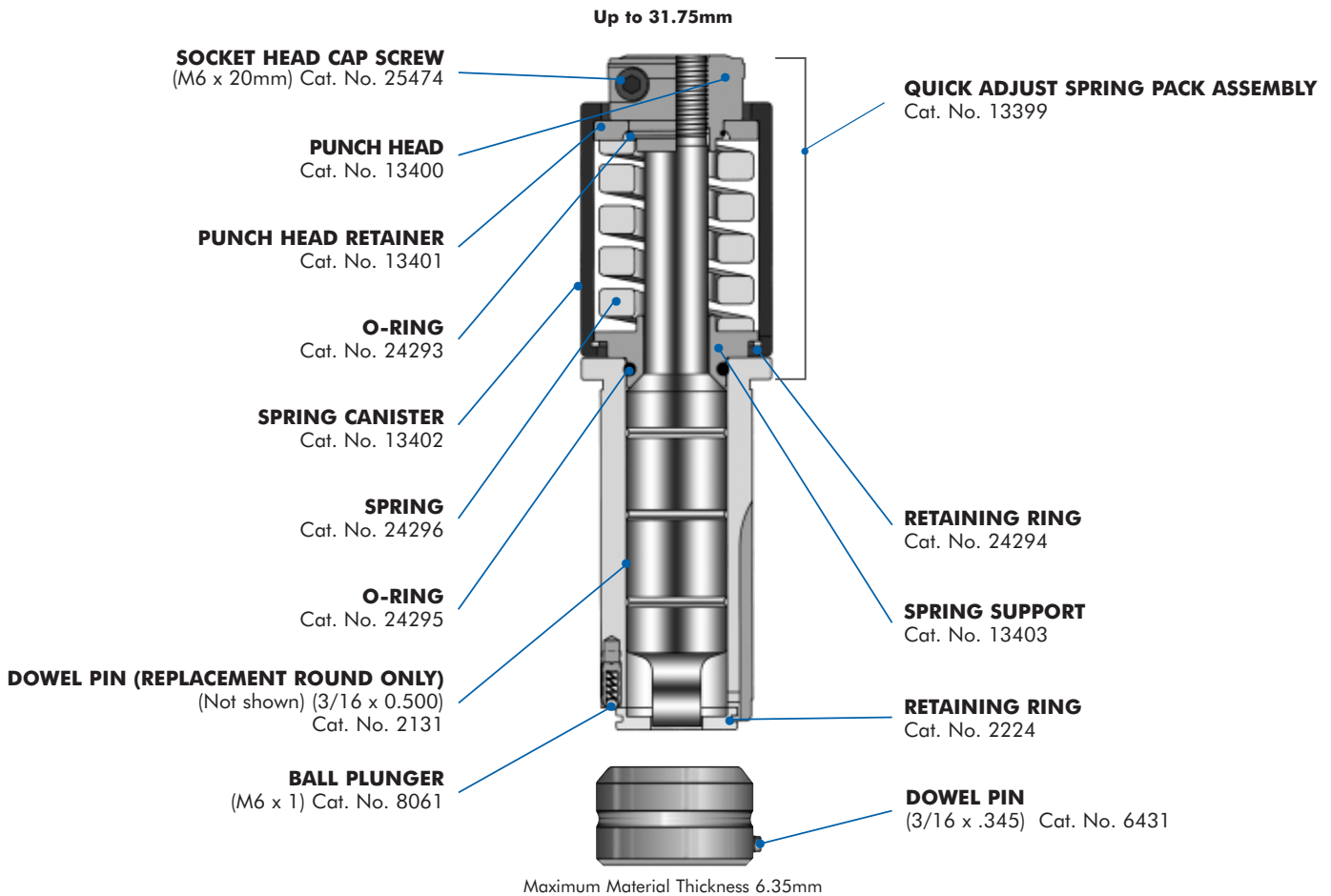

Description	Cat. No.	Price
Punch & Guide Assembly	• Round	13431
	• Shape Fitted	13433
	• Optima® Add On	-
Punches	• Round	2185
	• Shape	2184
	• Optima® Add On	-
	• Round	13413
Guides	• Shape (0°)	13414
	• Shape (0° & 45°)	13415
	• Shape (0° & 90°)	13416
	• Round	1890
Stripper	• Shape Fitted	1917
	Dies	• Round Slug Hugger®†
• Round Standard		2021
• Shape Slug Hugger®†		2195
• Shape Positive		2025
• Shape Negative		2026
• Shape (0° & 45°) Positive		2263
• Shape (0° & 45°) Negative		2264
• Ultima™ Add On (Round)		-
• Ultima™ Add On (Shape)		-

(B) Station Add Ons			
Add ons for Rounds			
Small Diameter	Punch	Die	Stripper
0.79 - 1.50mm			N/C
Clearance < 0.10mm			N/C
Add ons for Shapes			
Small Widths	Punch	Die	Stripper
0.79 - 1.0mm			N/C
'A' Dimension* < 11.10mm	N/C	N/C	N/C
Clearance < 0.10mm			N/C

Add to round or shape punch for extra straight before radius, extra back taper, or no back taper.

Notes

† Slug Hugger® dies must be ordered punch size plus clearance. Size restrictions apply. Contact Sales Desk for further information (patented). Slug Hugger 2 available on request.

* 'A' Dimension = longest distance across shape.

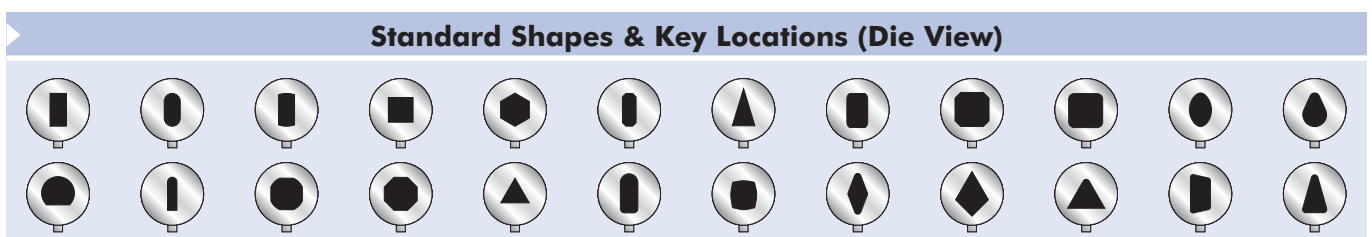

Wilson Amada Style B Station

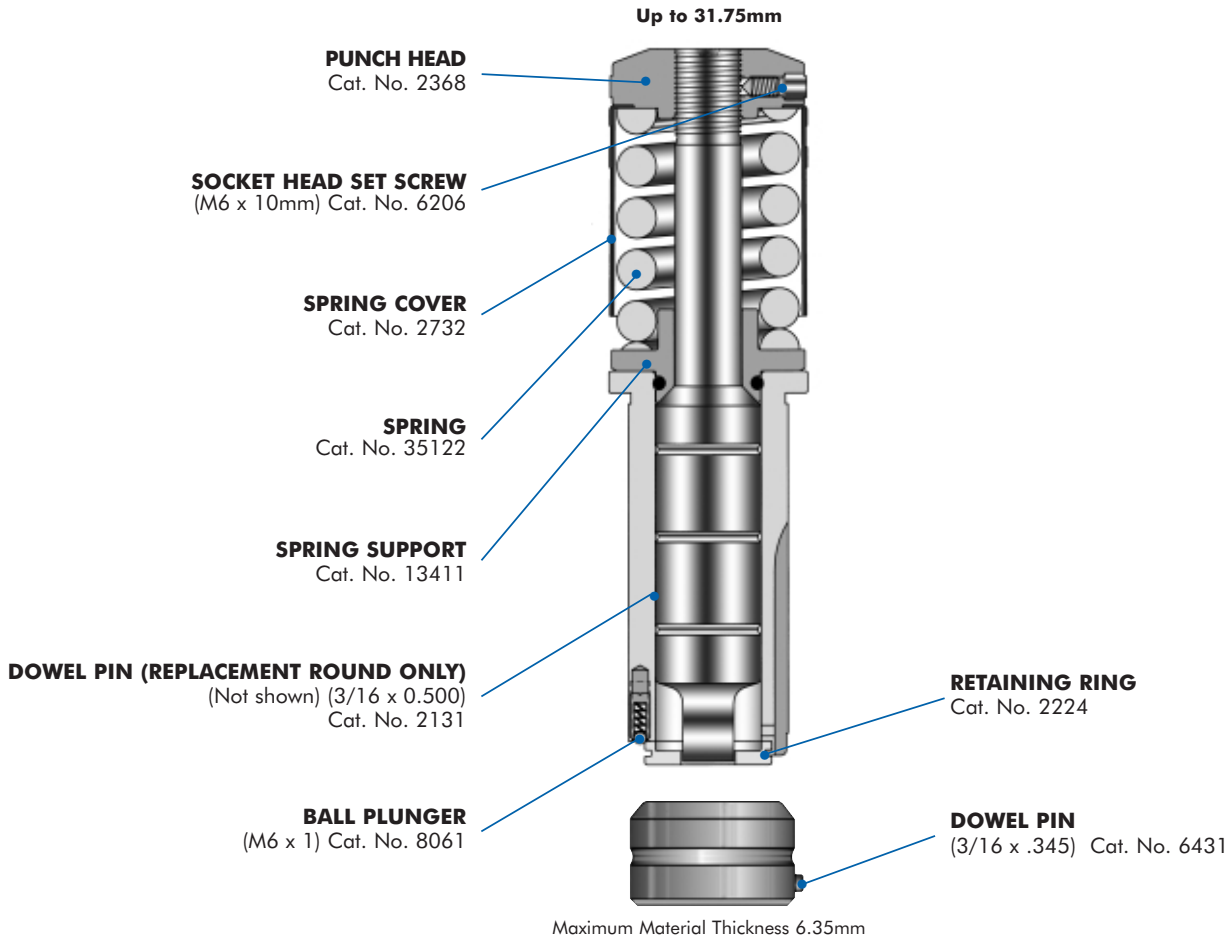

Description	Cat. No.	Price
Punch & Guide Assembly	• Round	13090
	• Shape Fitted	13092
	• Optima® Add On	-
Punches	• Round	2185
	• Shape	2184
	• Optima® Add On	-
	• Round	13413
Guides	• Shape (0°)	13414
	• Shape (0° & 45°)	13415
	• Shape (0° & 90°)	13416
	• Round	1890
Stripper	• Shape Fitted	1917
	Dies	• Round Slug Hugger®†
• Round Standard®†		2021
• Shape Slug Hugger		2195
• Shape Positive		2025
• Shape Negative		2026
• Shape (0° & 45°) Positive		2263
• Shape (0° & 45°) Negative		2264
• Ultima™ Add On (Round)		-
• Ultima™ Add On (Shape)	-	

(B) Station Add Ons			
Add ons for Rounds			
Small Diameter 0.79 - 1.50mm Clearance < 0.10mm	Punch	Die	Stripper
			N/C
			N/C
Add ons for Shapes			
Small Widths 0.79 - 1.0mm 'A' Dimension* < 11.10mm Clearance < 0.10mm	Punch	Die	Stripper
	N/C	N/C	N/C
			N/C

Add to round or shape punch for extra straight before radius, extra back taper, or no back taper.

Notes

† Slug Hugger® dies must be ordered punch size plus clearance. Size restrictions apply. Contact Sales Desk for further information (patented). Slug Hugger 2 available on request.

* 'A' Dimension = longest distance across shape.

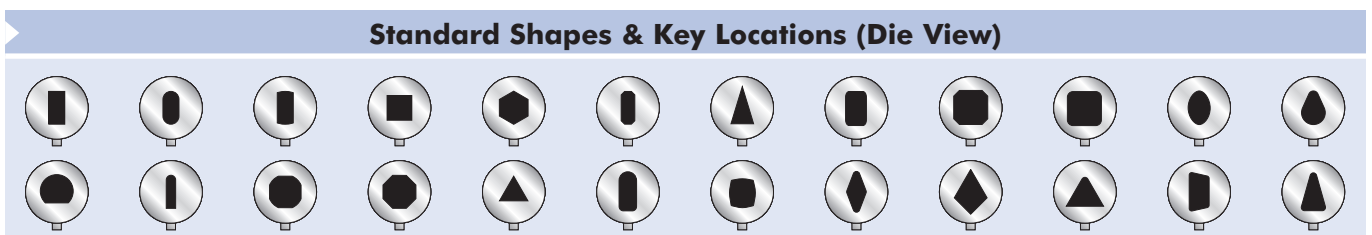

Wilson Amada Style C Station

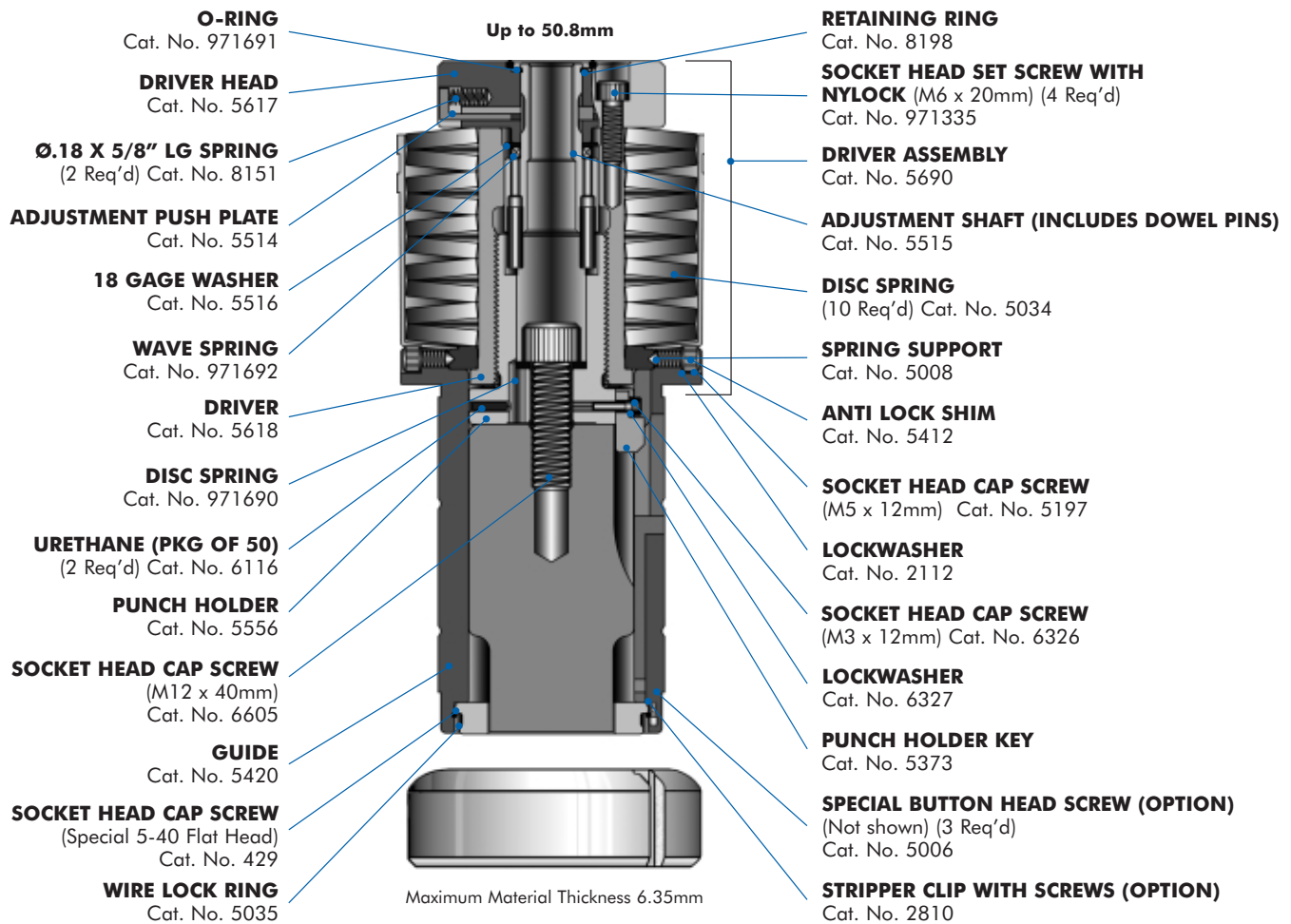

Description	Cat. No.	Price
Guide Assembly	• Standard	5583
	• Standard (LVD)	35191
	• Standard WLS®	5592
	• Standard WLS® (LVD)	35193
Punches	• Round	1933
	• Shape	1934
	• Optima® Add On	-
Strippers	• Round	1848
	• Shape	1854
Dies	• Round Slug Hugger®†	2196
	• Round Standard	1850
	• Shape Slug Hugger®†	2197
	• Shape Positive	1855
	• Shape Negative	1856
	• Ultima™ Add On (Round)	-
• Ultima™ Add On (Shape)	-	

50.8mm (C) Station Add Ons			
Add ons for Rounds			
Small Diameter < 25.4mm Clearance < 0.10mm	Punch	Die N/C	Stripper N/C N/C
Add ons for Shapes			
Small Widths 0.79 - 1.0mm 1.01 - 2.34mm Small 'A' Dimension* < 29.21mm 29.22 - 31.72 Clearance < 0.10mm	Punch N/C	Die N/C N/C N/C	Stripper N/C N/C N/C
Add to round or shape punch for extra straight before radius, extra back taper, or no back taper.			

Notes

Standard guide assys. are keyed for shapes at 0°, 90° and 225°.

All punches will be shipped with no shear unless specified.

†Slug Hugger® dies must be ordered punch size plus clearance. Size restrictions apply. Contact Sales Desk for further information (patented). Slug Hugger 2 available on request.

*'A' Dimension = longest distance across shape.

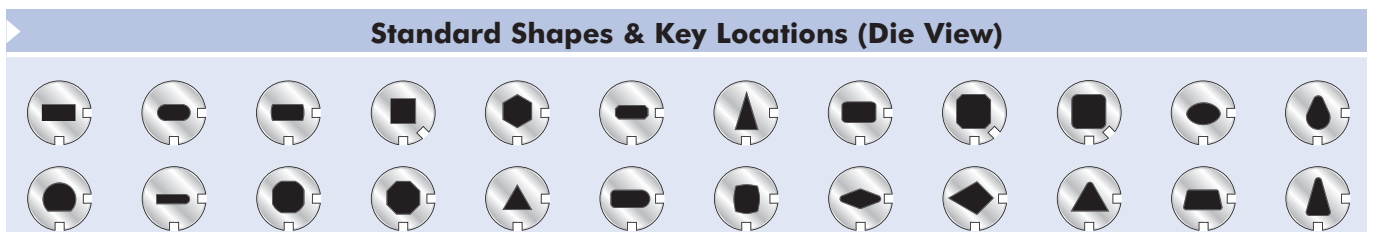

Wilson Amada Style D Station

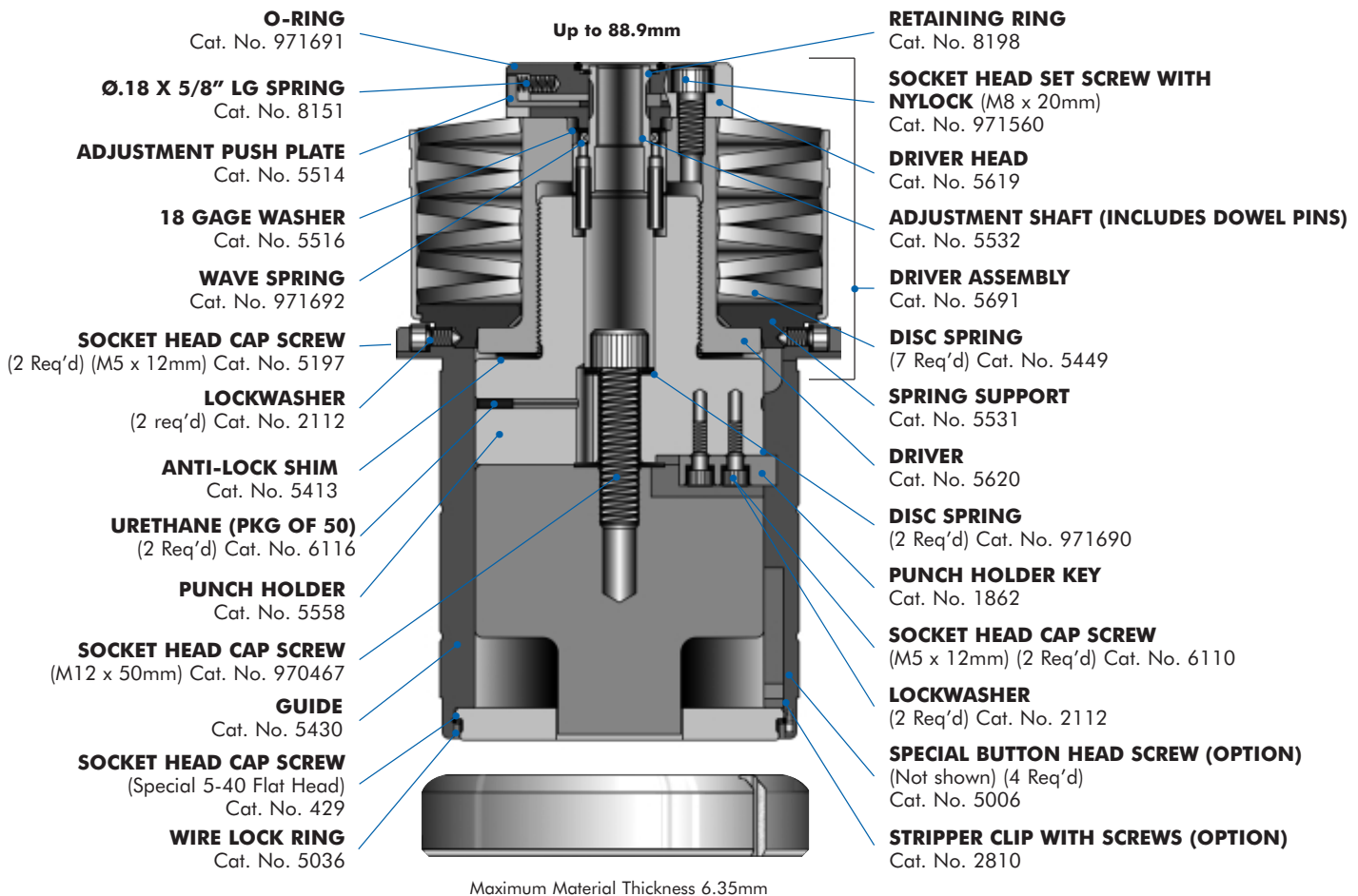

Description	Cat. No.	Price
Guide Assembly	• Standard	5584
	• Standard (LVD)	35198
	• Standard WLS®	5593
	• Standard WLS® (LVD)	35200
Punches	• Round	1937
	• Shape	1938
	• Optima® Add On	-
Strippers	• Round	1864
	• Shape	1869
Dies	• Round Slug Hugger®†	2198
	• Round Standard	1865
	• Shape Slug Hugger®†	2199
	• Shape Positive	1870
	• Shape Negative	1871
	• Ultima™ Add On (Round)	-
	• Ultima™ Add On (Shape)	-

88.9mm (D) Station Add Ons			
Add ons for Rounds			
Small Diameter 48.26mm 48.27 - 50.77mm Clearance < 0.10mm	Punch	Die N/C N/C	Stripper N/C N/C N/C
Add ons for Shapes			
Small Widths 0.79 - 1.0mm 1.01 - 2.34mm Small 'A' Dimension* < 48.26mm 48.27 - 50.77mm Clearance < 0.10mm	Punch N/C	Die N/C N/C N/C	Stripper N/C N/C N/C
Add to round or shape punch for extra straight before radius, extra back taper, or no back taper.			

Notes	
Standard guide assys. are keyed for shapes at 0°, 90° & 225°.	shipped with no shear unless specified.
1.6mm Rooftop shear is given to all punches with 'A' dimension greater than 50.8mm, and width greater than 6.35mm, at no extra charge.	† Slug Hugger® dies must be ordered punch size plus clearance. Size restrictions apply. Contact Sales Desk for further information (patented). Slug Hugger 2 available on request.
All punches 6.35mm and under in width will be	*A' Dimension = longest distance across shape.

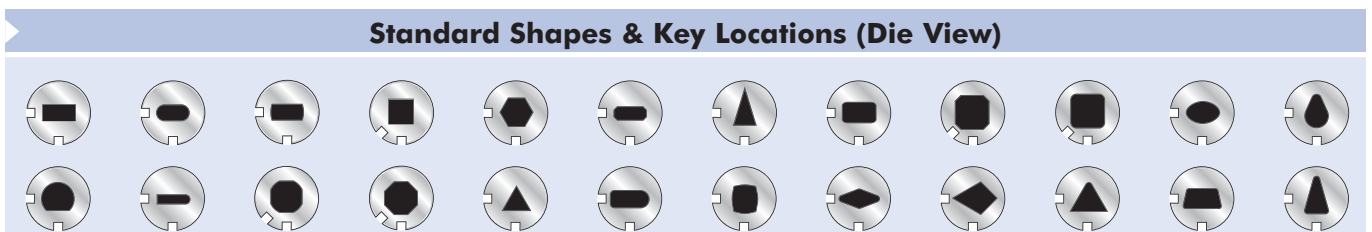

Wilson Amada Style E Station

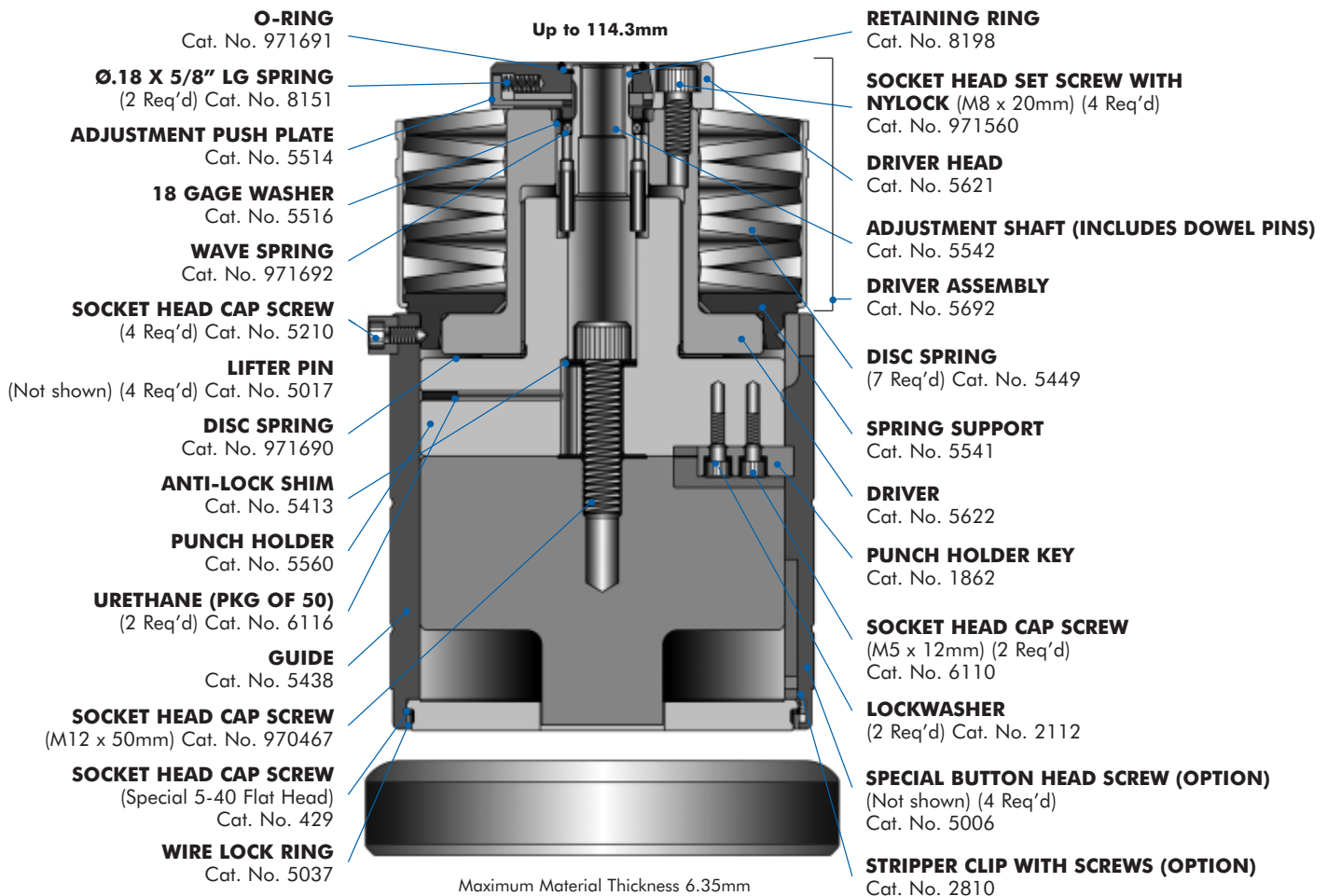

Description	Cat. No.	Price
Guide Assembly	• Standard	5585
	• Standard WLS®	5594
Punches	• Round	1941
	• Shape	1942
	• Optima® Add On	-
Strippers	• Round	1877
	• Shape	1882
Dies	• Round Slug Hugger®†	2200
	• Round Standard	1878
	• Shape Slug Hugger®†	2201
	• Shape Positive	1883
	• Shape Negative	1884
	• Ultima™ Add On (Round)	-
• Ultima™ Add On (Shape)	-	

114.3mm (E) Station Add Ons			
Add ons for Rounds			
Small Diameter < 86.36mm 86.37 - 88.87mm Clearance < 0.10mm	Punch	Die N/C N/C	Stripper N/C N/C N/C
Add ons for Shapes			
Small Widths 0.79 - 1.0mm 1.01 - 2.34mm Small 'A' Dimension* < 86.36mm 86.37 - 88.87mm Clearance < 0.10mm	Punch N/C	Die N/C N/C N/C	Stripper N/C N/C N/C
Add to round or shape punch for extra straight before radius, extra back taper, or no back taper.			

Notes	
Standard guide assys. are keyed for shapes at 0° & 90°.	be shipped with no shear unless specified.
1.6mm Rooftop shear is given to all punches with 'A' dimension greater than 50.8mm, and width greater than 6.35mm, at no extra charge.	† Slug Hugger® dies must be ordered punch size plus clearance. Size restrictions apply. Contact Sales Desk for further information (patented). Slug Hugger 2 available on request.
All punches 6.35mm and under in width will	* 'A' Dimension = longest distance across shape.

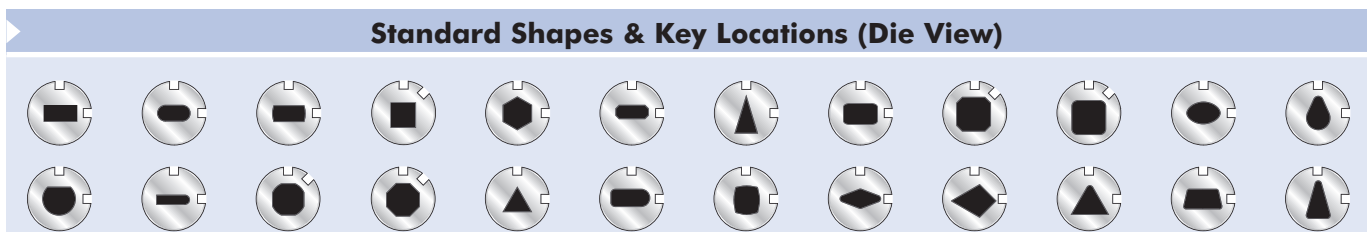

Close to Clamps Tooling



88.9mm (D) Station for punching close to clamps

Description	Cat. No.	Price
Dies		
• Slug Hugger [®] † (relief 2 sides, shp at 90°)	5157	
• Slug Hugger [®] † (relief 2 sides, shp at 0°-90°)	5330	
• Slug Hugger [®] † (relief 1 side, shp at 90°)	2464	
• Slug Hugger [®] † (relief 1 side, shp at 0°-90°)	5333	
• Positive (relief 2 sides, shp at 90°)	5101	
• Positive (relief 2 sides, shp at 0°-90°)	5328	
• Positive (relief 1 side, shp at 90°)	2462	
• Positive (relief 1 side, shp at 0°-90°)	5331	
• Negative (relief 2 sides, shp at 90°)	5156	
• Negative (relief 2 sides, shp at 0°-90°)	5329	
• Negative (relief 1 side, shp at 90°)	2463	
• Negative (relief 1 side, shp at 0°-90°)	5332	
• Ultima Add On	-	

114.3mm (E) Station for punching close to clamps

Description	Cat. No.	Price
Dies		
• Slug Hugger [®] † (relief 2 sides, shp at 90°)	5159	
• Slug Hugger [®] † (relief 2 sides, shp at 0°-90°)	5340	
• Slug Hugger [®] † (relief 1 side, shp at 90°)	2467	
• Slug Hugger [®] † (relief 1 side, shp at 0°-90°)	5343	
• Positive (relief 2 sides, shp at 90°)	5095	
• Positive (relief 2 sides, shp at 0°-90°)	5338	
• Positive (relief 1 side, shp at 90°)	2465	
• Positive (relief 1 side, shp at 0°-90°)	5341	
• Negative (relief 2 sides, shp at 90°)	5158	
• Negative (relief 2 sides, shp at 0°-90°)	5339	
• Negative (relief 1 side, shp at 90°)	2466	
• Negative (relief 1 side, shp at 0°-90°)	5342	
• Ultima Add On	-	

Notes

† Slug Hugger[®] dies must be ordered punch size plus clearance. Size restrictions apply. Contact Sales Desk for further information (patented).

* 'A' Dimension = longest distance across shape.

Replaceable Insert Assembly

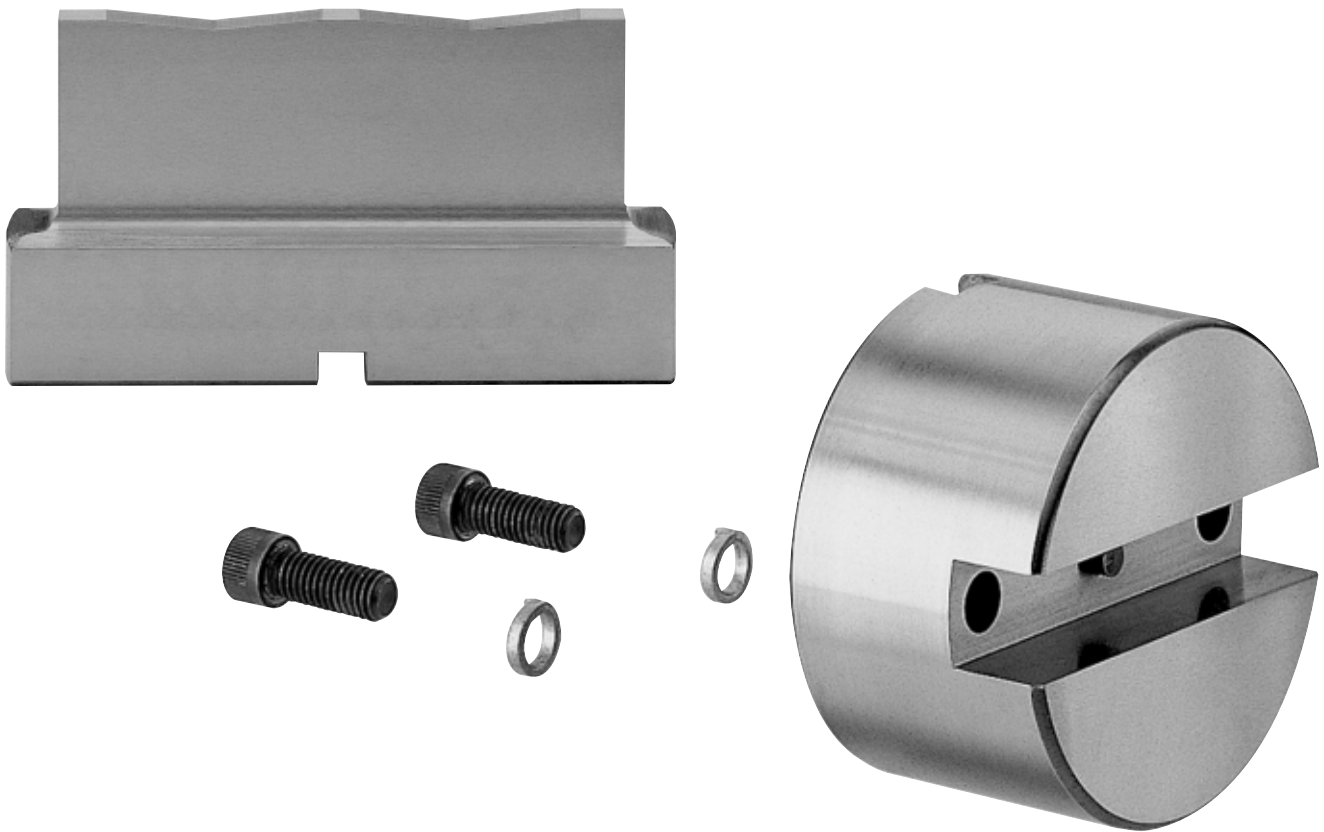

Replaceable Insert Assembly

Station	Body (1/2" - 13)		Body (M - 12)		Punch Insert		Set (1/2" - 13)		Set (M - 12)	
	Cat. No.	Price	Cat. No.	Price	Cat. No.	Price	Cat. No.	Price	Cat. No.	Price
50.8mm (C)	2623		2625		2590		2568		2624	
88.9mm (D)	1966		2286		1967		1965		2372	
114.3mm (E)	1969		2287		1970		1968		2373	

Parts Description	Cat. No.	Price
Socket Head Cap Screw – 3/8" - 16 x 1-1/2" long (for 50.8mm (C) station)	6391	
Socket Head Cap Screw – 3/8" - 16 x 1-1/2" long (for 88.9mm (D) & 114.3mm (E) stations)	6019	
High Collar Lock Washer for 3/8" screw	2129	
Dowel Pin – 1/4" Dia. x 450" long (All stations)	6004	

Notes

- * Optima® is standard on punch inserts.
- * Blade insert punches under 9.53mm in width will be shipped with no shear unless specified.
- * Double Valley Shear is recommended for widths of 4.75mm up to 9.53mm and minimum lengths of 50.8mm when used for nibbling.
- * Undersized dimensions will incur additional charges. Please consult the fee schedule for the appropriate station to determine the charge.
- * See shear chart on page 17.
- * For widths less than 2.36mm, consult the sales desk.
- * Maximum width 19mm.
- * Inserts are available as obround to be used with rectangle dies, to eliminate 'Saw Tooth Effect'.

Punch Shims, Die Shims and Slug Ejectors

Die Shims

Station	Quantity	Cat. No.	Price
0.25mm Thick – Individually			
12.7mm (A)	1	2101	
31.75mm (B)	1	2097	
50.8mm (C)	1	2089	
88.9mm (D)	1	2081	
114.3mm (E)	1	2073	
0.25mm Thick – Package			
12.7mm (A)	25	2208	
31.75mm (B)	25	2209	
50.8mm (C)	10	2210	
88.9mm (D)	5	2211	
114.3mm (E)	5	2212	
0.75mm Thick – Individually			
12.7mm (A)	1	2721	
31.75mm (B)	1	2723	
50.8mm (C)	1	2725	
88.9mm (D)	1	2727	
114.3mm (E)	1	2729	
0.75mm Thick – Package			
12.7mm (A)	25	2722	
31.75mm (B)	25	2724	
50.8mm (C)	10	2726	
88.9mm (D)	5	2728	
114.3mm (E)	5	2730	
1.5mm Thick – Individually			
12.7mm (A)	1	2104	
31.75mm (B)	1	2100	
50.8mm (C)	1	2092	
88.9mm (D)	1	2084	
114.3mm (E)	1	2076	
1.5mm Thick – Package			
12.7mm (A)	25	2172	
31.75mm (B)	25	2173	
50.8mm (C)	10	2174	
88.9mm (D)	5	2175	
114.3mm (E)	5	2176	

Punch Shims

Station	Quantity	Cat. No.	Price
Individually			
12.7mm (A)	1	13080	
31.75mm (B)	1	152	
50.8mm (C)	1	2096	
88.9mm (D)	1	2088	
114.3mm (E)	1	2080	
Package			
31.75mm (B)	25	98	
50.8mm (C)	10	2169	
88.9mm (D)	5	2170	
114.3mm (E)	5	2171	

Slug Ejectors

Square Urethane			
Hole Diameter in Punch	Quantity	Cat. No.	Price
3.2mm	50	6116	
4.8mm	50	6117	
9.5mm	50	6118	
12.7mm	50	6119	
Assortment	50	6410	

Non Standard Keying

When ordering shapes at non-standard angles, use the diagrams below to eliminate any confusion.

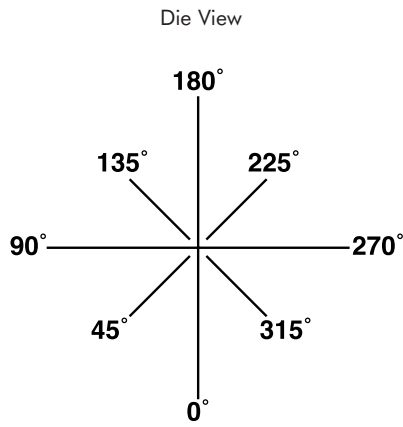

Front of Machine

Wilson Tool's keying diagram.

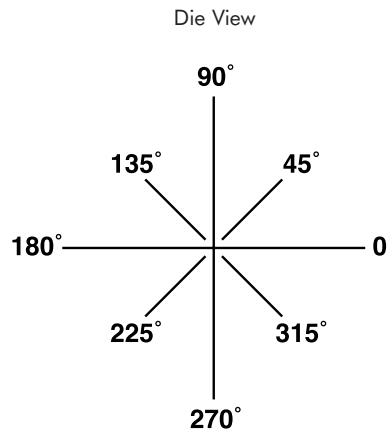

Front of Machine

This key location matches Amada's® turret punch press programming method.

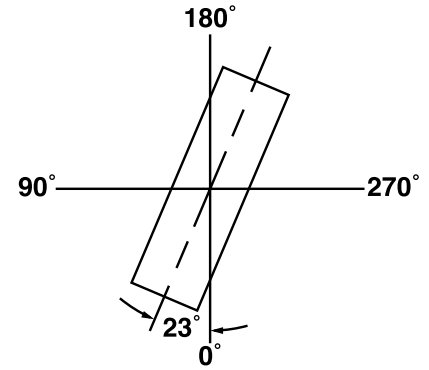



Example

Shape at 23°

Shape at single angles other than standard (Note: No additional charge on A & B Stations for shape at 45° increments)			
Station	Punches	Dies	Guides or Strippers
12.7mm (A)	No Charge		No Charge
31.75mm (B)			Not Applicable
50.8mm (C)			Not Applicable
88.9mm (D)			Not Applicable
114.3mm (E)			Not Applicable

Standard Keying, plus extra pins or keys for shapes at other than 45° increments			
Station	Punches	Dies	Guides or Strippers
12.7mm (A)	Not Available	Not Available	per key
31.75mm (B)	Not Available	Not Available	per key
50.8mm (C)	per pin	per key	Not Applicable
88.9mm (D)	per pin	per key	Not Applicable
114.3mm (E)	per pin	per key	Not Applicable

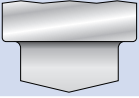
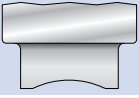
Standard Keying, plus extra pins or keys for shapes at 45° increments					
Station	Punches		Dies		Guides or Strippers
	Available Options	Add On Price	Available Options	Add On Price	
12.7mm (A)	Not available	Not available	Not available	Not available	per key
31.75mm (B)	0° & 45°		0° & 45°		per key
	0° & 180°		0° & 180°		per key
50.8mm (C)	45° Increments	per pin	45° Increments	per key	Not applicable
88.9mm (D)	45° Increments	per pin	45° Increments	per key	Not applicable
114.3mm (E)	45° Increments	per pin	45° Increments	per key	Not applicable

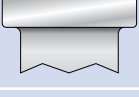
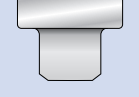
Type of Shear	Benefit	Limitation
 Rooftop	Best shear for punching at maximum tonnages.	When nibbling, bite must be 75% of punch dimension or excessive side loading will result.
 Concave or Double Concave	Best shear for nibbling because it inverts stresses.	The punch is less resistant to breakage when punching at high tonnages because of inverted stresses.
 Inverted Rooftop	Also good shear for nibbling because it inverts stresses.	More susceptible to breakage because of a sharp focal point for stresses – use with great care.
 Double Valley Shear	Best shear for nibbling when shape is long and narrow.	The punch is less resistant to breakage when punching at high tonnages because of inverted stresses.
 JK Shear	A special punch tip shear that allows you to punch high strength materials with a reduced risk of breakage.	Can only be used on punches up to 25.4mm diameter or 'A' dimension*.

Special Shears

Station	'A' Dimensions*	Inverted Rooftop		Double Valley	
		Single Concave		Double Concave	
		1.6mm Shear	3.2mm Shear	1.6mm Shear	3.2mm Shear
31.75mm (B)	Within 31.75mm		N/A		N/A
50.8mm (C)	Within 50.8mm				
88.9mm (D)	Within 88.9mm				
114.3mm (E)	Within 114.3mm				

JK Shear

Shape	Add on Price
Round	
Rectangle, Square, Hexagon	
Single 'D', Double 'D'	
Obround	

Die Clearance Selection Information

% Total Clearance			
Material	Minimum	Best	Maximum
Copper, 1/2 Hard	8	12	16
Brass, 1/2 Hard	6	11	16
Mild Steel	10	15	20
Steel 0.50C	12	18	24
Aluminium, Soft	5	10	15
Stainless Steel	15	20	25

% x Material Thickness = Total Clearance

Notes

If specified: 3.2mm maximum rooftop shear can be given at N/C for any round or shape in 50.8mm (C), 88.9mm (D) or 114.3mm (E).

For rooftop shear on any round or shape in 12.7mm (A) or 31.75mm (B) stations, add

• 1.6mm rooftop shear is given to all punches with 'A' dimension* greater than 50.8mm and width greater than 6.35mm at no extra charge. All punches 6.35mm and under in width will be shipped with no shear unless specified.

*'A' Dimension = Longest distance across shape.

••NOTE: In some instances, inverted rooftop is substituted for single and double concave shears.